

No.	NAME OF PART	Q'TY	M T L	REMARKS
1	Body	1	ADC12	
2	Driving Unit Cover	1	ADC12	
3	Position Indicator 0~90° 10div.	1	GLASS	
4	Electric Unit Cover	1	ADC12	
5	Control Unit Cover	1	ADC12	
6	Wiring Hole	2	—	NPT1/2
7	Manual Handle Shaft	1	S45C	
8	Output Shaft	1	SUS304	
9	Stopper	1	SCS13	
10	Stopper Bolt/Nut	2	SUS304	

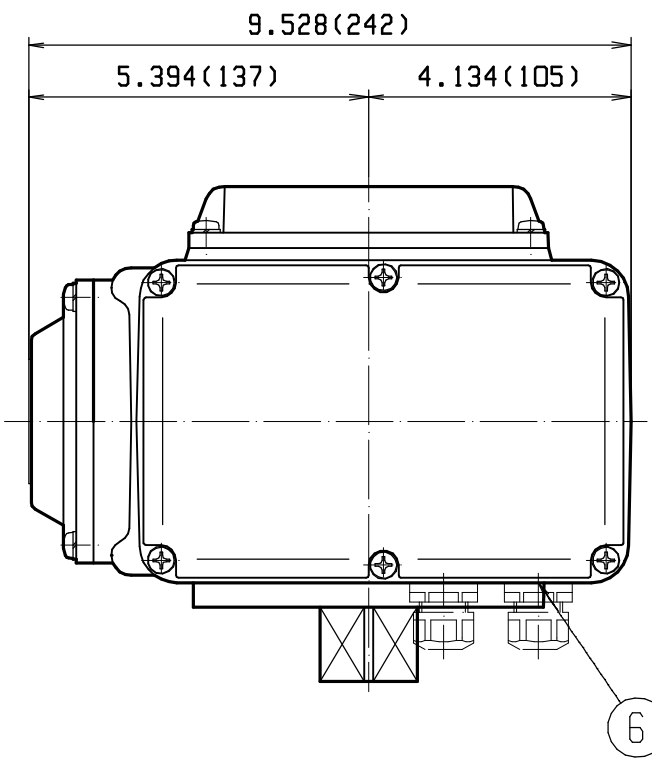
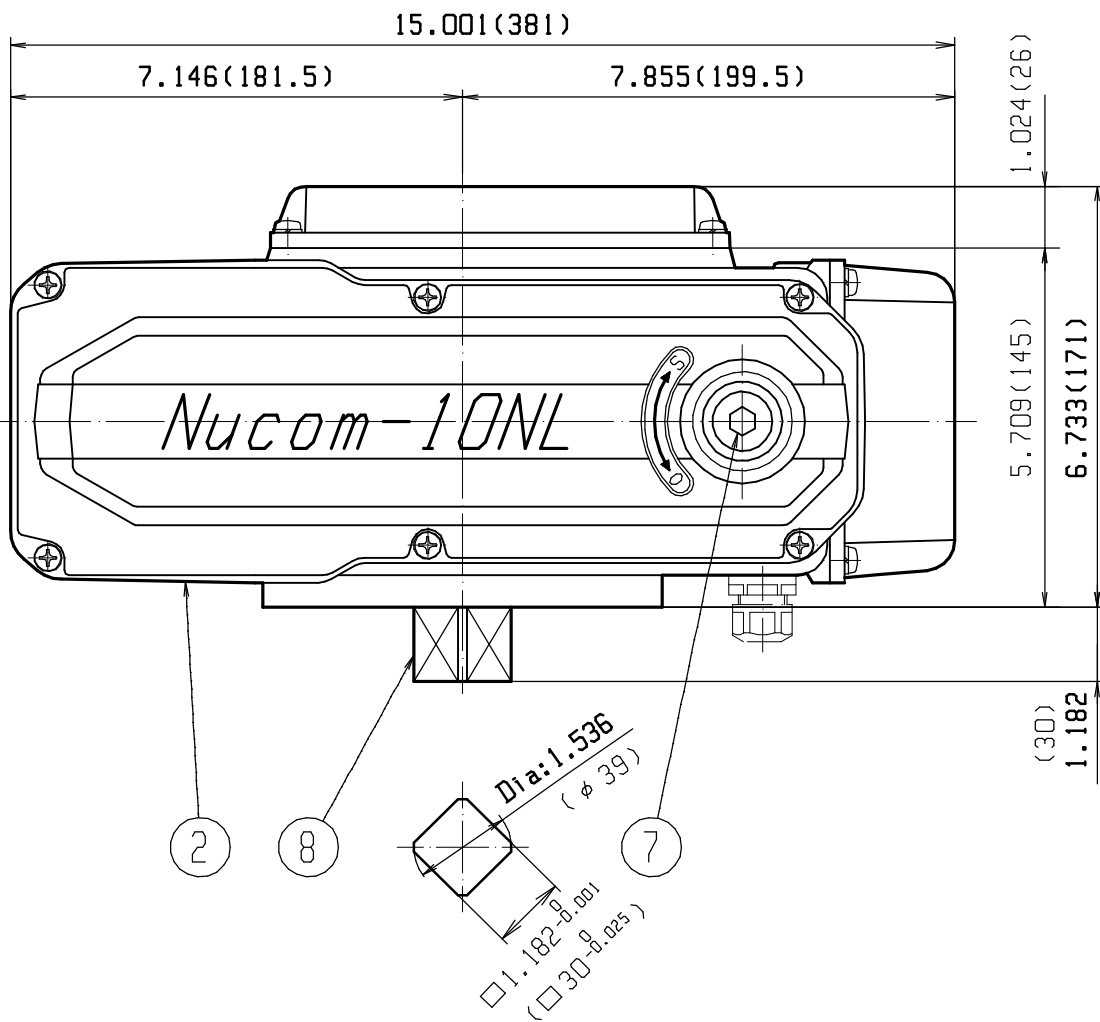
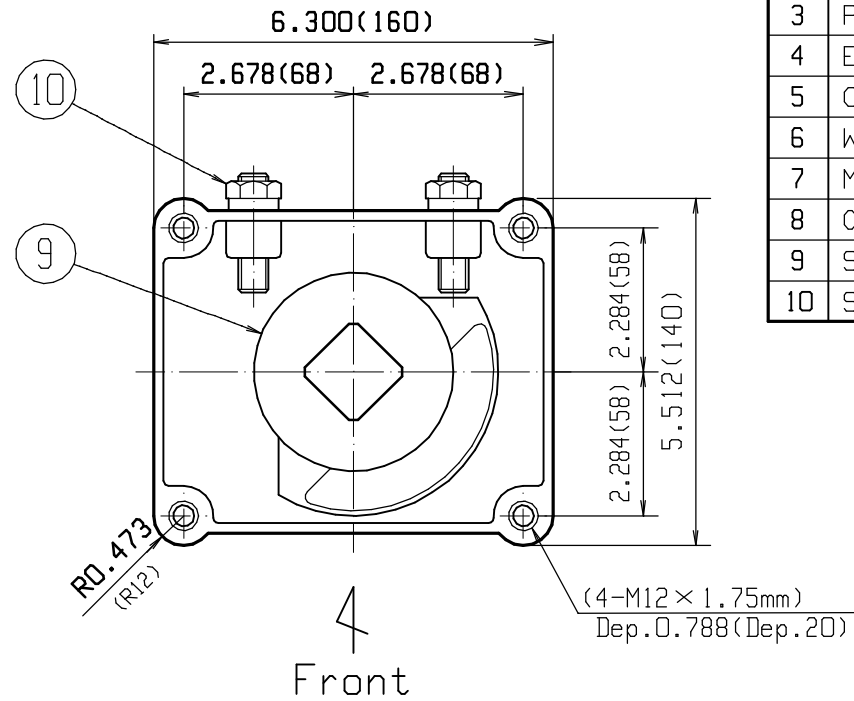
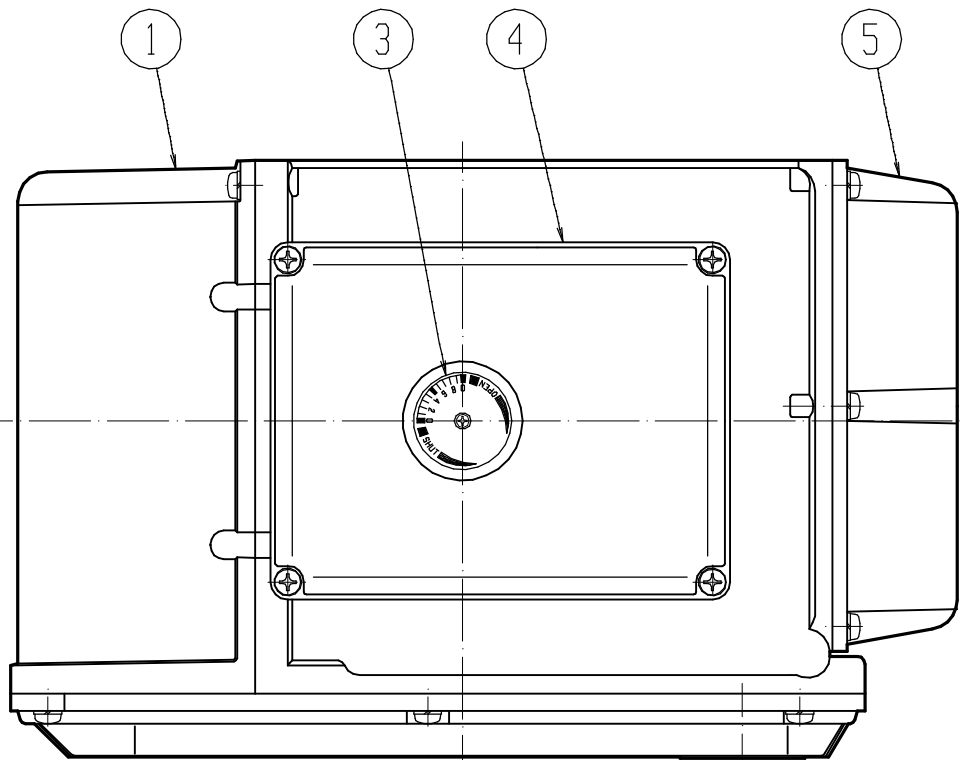

CERTIFICATE OF COMPLIANCE		
TYPE	CERTIFICATE NUMBER	ISSUED BY
NEMA-4,4X	130198-E177862	UL
CSA.NRTL/C	LR110832-1,2	CSA
CE	EMS 1B0704-1,2	ASSESSMENT SERVICE

DRIVING UNIT SPECIFICATION	
POWER SOURCE	AC115V · 120V · 240V 60Hz Single phase
CONTROL ANGLE	0~90° degree.
OPERATION SPEED	25sec./90deg.
OUTPUT SHAFT TORQUE	8680in-lb(980.66N·m)
MANUAL OPERATION	Available
INPUT SIGNAL	4~20mA · DC
RESOLUTION	Over 1/250
BODY MATERIAL	Aluminium diecast
COATING COLOR	Gray(N-6)
BODY WEIGHT	22 kg

OUTPUT SHAFT POSITION : 0 %
DIMENSIONS ARE Inch(mm)

NAME: ACTUATOR OUTER DIMENSIONS	DATE	SIGN
MODEL: Nucom-10NL-100	APRV.	
	CONF.	
	DRAW. 05, JUN, '02	K. SUGIYAMA
KOEI INDUSTRY CO., LTD.	DR. No,	27010GE2